

Sample taking and preparation



Individual units and complete installations

International standards

have been produced for sampling and sample preparation by the most varied committees and on all continents for many years now. Unfortunately, these standards in their most sophisticated form for iron ore and coal have been becoming increasingly more theoretical and thus evermore difficult to understand for the layperson.

The uncertainty when working with these standards or drafts for such standards is aggravated still further by possible interpretations varying, deviations amongst different national standards (such as DIN, ASTM, BIS, JIS, ...) and in relation to ISO standards.

For this reason, the fundamentals of sampling will be gone into in detail in this brochure. In this manner, even a layperson will be able to differentiate as to what extent representative sampling is involved, and what it means if too little importance is attached to sampling.



Sampling system for coal, ship's loading, Qinhuangdao, China
Project management in cooperation with our sister company **TEMA B.V.** 

General considerations concerning quality control

Information about the properties of raw materials and products is an absolute must: On the one hand, to determine essential properties for using them, on the other hand, to characterise the quality in such a manner that prices can be calculated and comparisons of prices made.

To determine the quality characteristics, partial amounts are to be taken from the quantity of material to be sampled (sampling), which after appropriate processing (sample preparation) are to be tested.

Of the process stages requisite to determine the quality characteristics, such as sampling, sample preparation

and laboratory tests, much too little attention is paid to the first two stages compared to the latter. It is, however, a fact that even when the recognised rules and regulations are carefully adhered to the proportion of an accidental and avoidable error in sampling and sample preparation is many times greater than the proportion of an analysis error in slip-ups all told.

The quality characteristics determined by the laboratory with high analytical accuracy can only be reliable as the precision of the sampling and sample preparation enables them to be.

If we now take into account the economic repercussions of wrong testing, the significance of exact sampling and sample preparation can readily be appreciated.

Today, there is machinery and equipment available for sampling and sample preparation, which work largely accurately and reliably even in fully automatic operation.

However, in order to set-up a functional sampling plant, it is absolutely essential to adapt it to the local conditions of the location where sampling is to be done, and to integrate the procedurally meaningful machinery and equipment in the right configuration.

Alongside financial and technical viewpoints, the normative requirements must be mostly focused on for a sampling plant's design to be able to secure representative sampling. However, local conditions are not always in accord with the stipulations in the standards.

In such cases, it should be checked to ascertain to what degree any necessary deviation from the theoretical requirements may take effect. Once a sampling plant has been set up, it should therefore be subject to an acceptance test to safeguard its proper and reliable operation.

Hammer-Sampler
 No. of Incr./Lot = 67
 No. of Incr./h = 84
 Interval = 43 s
 Slot = 150 mm
 Primary Incr. = 46,6 kg

Feeding conveyor B-B 400
 Eff. capacity = 4,79 t/h (46,6 kg / 35 s)
 Average capacity = 3,913 t/h

Crusher-Type 50/40
 Max. Grain size = 50 mm (max. 100 mm)
 Final Grain size = < 10 mm
 Max. capacity = 11 t/h
 Eff. capacity = 4,79 t/h

2-Step Divider 900/500 (900 mm dia: 500 mm dia)
 Dividing = 1:185
 Eff. capacity = 4,79 t/h

Sample Collector 6/30
 Final sample/h = 21,2 kg
 Final sample/Lot = 1,429 kg

Other flow rates shown in diagram:
 3,892 t/h (at 1.8 and 1.9)
 3,913 t/h (at 1.0, 1.1, 1.2, 1.3, 1.4, 1.5)
 21,2 kg/h (at 1.6)

reversible (at 1.9)

Automatic sample taking and preparation system for coal, train unloading, Qinhuangdao, China
 Project management in cooperation with our sister company **TEMA B.V.**

Fundamentals of sampling and sample preparation

To be understood under the term “sampling” are all work procedures necessary to remove a quantity of samples in such a manner that they largely correspond to the total quantity with regard to quality and without systematic errors.

Subsequent “sample preparation” includes all requisite work procedures to bring the sample material obtained in sampling into the condition prescribed for the subsequent examinations.

During sampling, please bear in mind that bulk material - particularly raw materials and preliminary products - are frequently very inhomogeneous in the quality characteristics essential for assessment.

The more non-uniform the material is, the more intensive sampling is to be carried out in order to obtain a sample representative for the entire amount.

Due to the fact that removal of an extremely large number of samples and processing to large collection samples is very costly, the number of samples to be taken must be precisely co-ordinated to match the composition of the material to be sampled.



Sampling system for iron ore, ship's unloading, Beilun, China
Project management in cooperation with our sister company **TEMA B.V.**

The number and volume of the individual samples depend essentially on the mass (i.e. the total amount to be sampled for which a parameter is to be determined = lot), on the granular size and on the homogeneity of the material to be sampled.

To be taken into account in subsequent sample preparation is that the collection sample from the individual samples reflects the homogeneity of the material to be sampled. In all work procedures, please take special care to ensure that the sample is prepared without loss of characteristics worth mentioning (e.g. water content).

The high requirements to be made on the technical execution of machinery and equipment for sampling and sample preparation arise, inter alia, from the very high proportion of the material quantity to be examined to the total amount to be assessed.

This can be explained using the example of ash content. For analysis, a sample quantity of a few grams is adequate, which, however, has to have the same ash content as the shipload of 100,000 tons, from which this sample was taken.

The demand for the analysis sample to be examined to correspond to the quality characteristics that are to be determined of the pertinent quantity delivered can be relatively simply determined on the moved material. All that has to be ensured is that the samples are taken over the entire cross section of the material stream in sufficient quantity and frequency.

Taking a representative sample from material that is stationary involves very great difficulties and almost invariably can only be realised in a limited manner.

The average sample to be taken for sampling ("random sample" in the statistical sense) comprises individual samples, the number of which depends on the material

quantity to be assessed and on the dispersion of the characteristics to be determined within the material quantity.

Should several quality characteristics have to be determined, the strongest dispersing characteristic is decisive for defining the number of individual samples.

When planning and executing such plants for sampling and sample preparation, the manufacturer should take special care to ensure that all machinery and equipment operate without systematic errors, and that deviations that may occur, for example, when separating sample material are as low as possible.

Automatic sample taking and preparation system for coal, ship's unloading, The Netherlands
 Project management in cooperation with our sister company **TEMA B.V.**

General directives for designing plants for sampling and sample preparation

As already mentioned, sampling can be mostly simply executed on moving material - when it is on a conveyor, conveyor transfer or in the downpipe. Here, care should be taken to ensure that each sample represents a cross-section sample of the material stream altogether. In other words, the material stream must be recorded in its entire width and thickness.

This sample is taken dependent on time or mass, i.e. either at the same time intervals or with the same mass intervals. Due to the fact that the time-dependent variant is more cost-effective, sampling is pre-dominantly executed through the same time intervals.

The slot width of the vessel used for sampling should be triple the material's maximum top size.

The nominal top size indicates the granular size, in which the residue on the pertinent screen must not be in excess of 5 %. A slot width of 30 mm should, however, not be fallen short of even with finer material.

The speed of the sampling equipment must remain constant during the entire sampling procedure. When samples are being taken from the material stream dropping, the passage speed of the vessel used for sampling should, where possible, not be greater than 0.6 m/s. Otherwise, a selection of the granular size would be made by the sampling vessel.

The material quantity incurred in sampling is decisive for the size of the sampling vessel and, when the sample frequency is taken into account, for the design of the downstream machinery and equipment for comminution, separation and collection of the sample material. The weight for one individual sample is calculated according to the following numerical value equation:

$$m_{EP} = \frac{\dot{m} \cdot SW}{v \cdot 3600}$$

- m_{EP} : mass of primary increment in kg
- \dot{m} : flow rate in t/h
- SW : lot width of vessel used for sampling in mm
- v : a) sampling at the head of the belt/in vertical chutes: speed of the sampling vessel in m/s
- b) sampling from moving belts: speed of the belt in m/s

Examples:

- a) Sampling of coal (< 50 mm) with slot vessel sample taker at the discharge point of a conveyor belt.

$$\dot{m} = 1200 \text{ t/h}; SW = 150 \text{ mm}; v_{\text{slot vessel sample taker}} = 0,6 \text{ m/s}$$

$$m_{EP} = \frac{1200 \cdot 150}{0,6 \cdot 3600} = 83,32 \text{ kg}$$

- b) Sampling of coal (< 50 mm) with hammer sample taker off the conveyor belt.

$$\dot{m} = 1200 \text{ t/h}; SW = 150 \text{ mm}; v_{\text{conveyor belt}} = 2,5 \text{ m/s}$$

$$m_{EP} = \frac{1200 \cdot 150}{2,5 \cdot 3600} = 20,00 \text{ kg}$$



Sampling system for coal in unloading crane

The sampler is to be adequately dimensioned in volume to that it never can be covered even under the most unfavourable operating conditions. Depending on the granular size and the type of further analyses intended, the sample material incurred is now to be comminuted for it to be divided.

When the comminution machine is selected, care should be taken in each comminution stage to ensure that machinery is implemented that does not cause the quality parameters to be falsified.

By way of example, when determining water content, work should never be conducted with a rapidly-running unit. Water loss can certainly be expected due to the

ventilator effect of this comminution machine.

When the samples are divided, care should be taken to ensure that the minimum quantities stipulated in the various standards are not fallen short of.

Should the sample to be separated fall short of the prescribed minimum quantity after dividing, collection should be made beforehand, so that with a larger collection sample a corresponding final quantity is achieved after dividing.

As a matter of principle, a comminution stage should be switched prior to any further partial step, reducing the granular size of the material and thus also further homogenising it.

Automatic sample taking and preparation system for sinter, China
 Project management in cooperation with our sister company **TEMA B.V.**

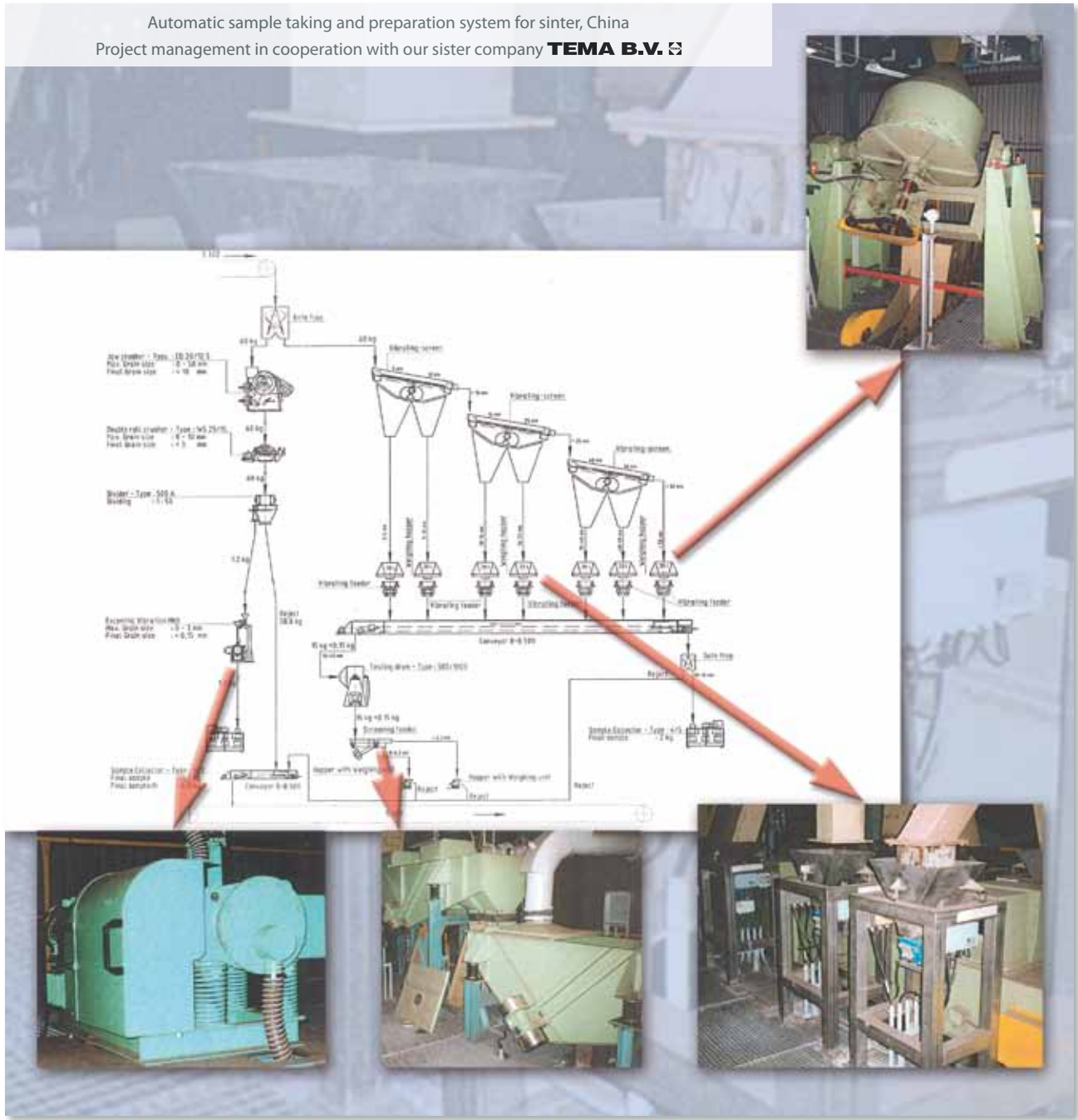

Machinery and equipment for sampling and sample preparation

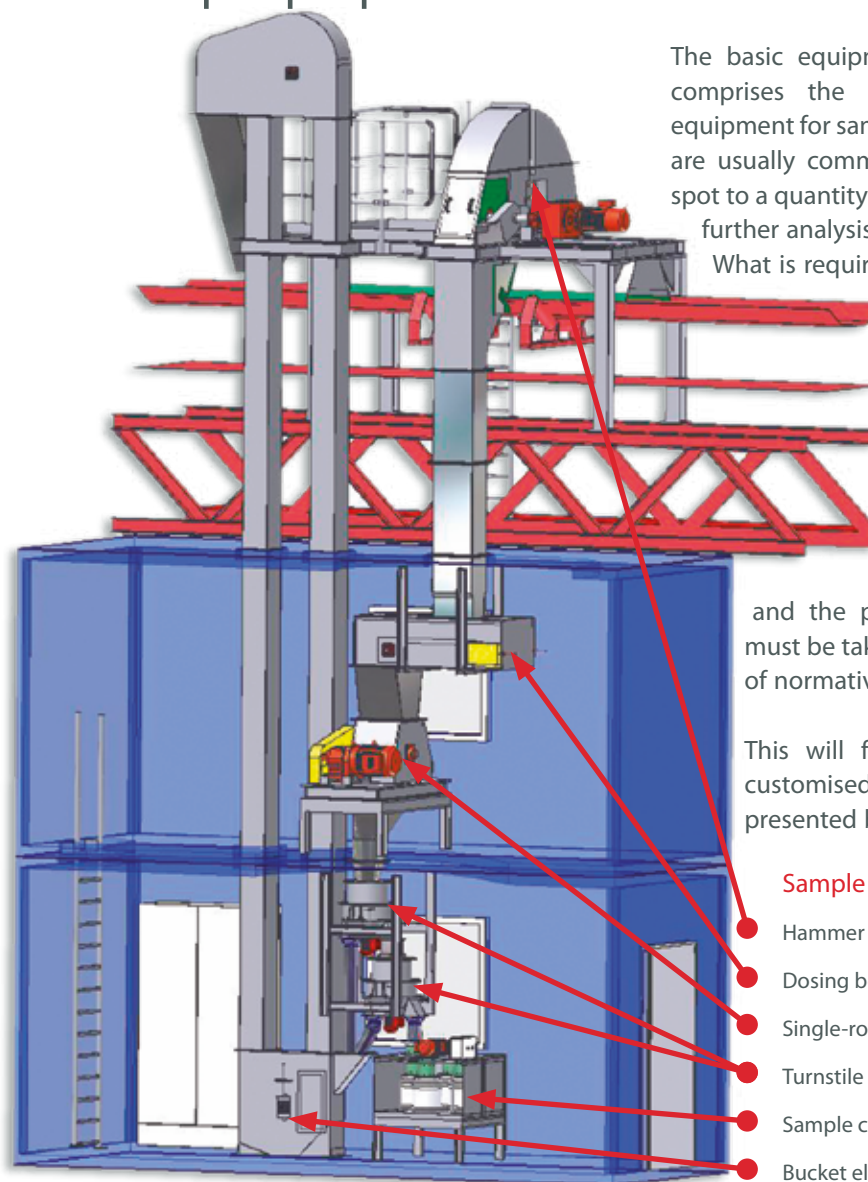

The basic equipment for a sampling system mostly comprises the sampling machine itself and the equipment for sample preparation. The sample amounts are usually comminuted and reduced directly on the spot to a quantity reasonable for the laboratory to make further analysis.

What is required here is at least one crushing stage and a dividing unit as well as the sample collector for keeping the sample material for a protracted period of time.

To set up a representative sampling plant, the quite different products, the local conditions where the plant is to be set up, and the performance varying in wide ranges must be taken into account - in addition to a host of normative requirements.

This will frequently necessitate an individual, customised solution from the two basic principles presented below.

Sample taking installation for coal

- Hammer sample taker
- Dosing belt
- Single-roller mill
- Turnstile divider
- Sample collector
- Bucket elevator



Hammer sampler for coal

Hammer sample taker

The hammer sampler is implemented for sampling materials from belt conveyors. The sampler's removal principle resembles that of the sampling frame, serving as this sampling frame that is closed on one side in a circular movement through the material stream moving on the belt. It thus automatically removes a representative cross-section sample from the belt, corresponding to that of the sampling frame.

To ensure that the belt is not damaged and to obtain

a complete and representative sample, the shape of the sampler must be adapted to the various belt cross sections and belt depressions.

Also included here is the use of brushes and rubber wipers that ensure that fine portions adhering to the belt base are discharged into the sample and do not remain on the belt.

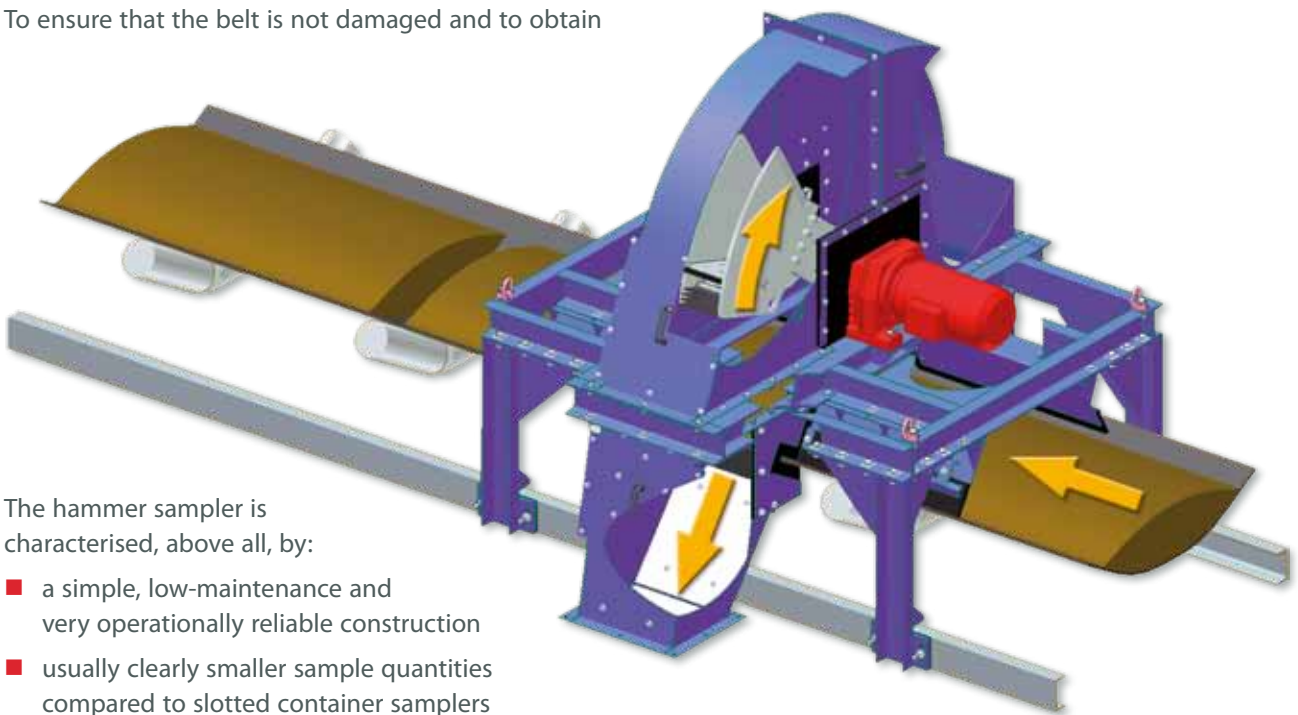

The hammer sampler is characterised, above all, by:

- a simple, low-maintenance and very operationally reliable construction
- usually clearly smaller sample quantities compared to slotted container samplers
- hardly any expenditure for changes to existing belt installations for retrofitting



Hammer sampler for limestone

Sample taking

2. Slotted vessel samplers

The slotted vessel sampler is implemented for sampling materials at the belt head or in the downpipe. This sampling principle is based on a slotted vessel with defined intake slot vertical to the dropping material stream that records the material stream's entire thickness at a constant speed.

The slotted vessel sampler runs through the material stream from the waiting position with the base flap usually opened, closing this flap when the reverse position is reached.

The sampler now runs through the product stream with the base flap closed again at constant speed and thus takes a representative sample.

On the usually conical vessel reaching its waiting position, the base flap is opened by means of stops and a sophisticated lever system, and the slotted vessel emptied.

The sampler's waiting position is invariably located outside the material stream, wear to the sampler thus being minimised.

The slotted vessel sampler is characterised, above all, by:

A construction enabling extremely good adaptation to be made to the given local conditions.

The possibility of new constructions in order to be able to realise a representative sample even at inaccessible spots.

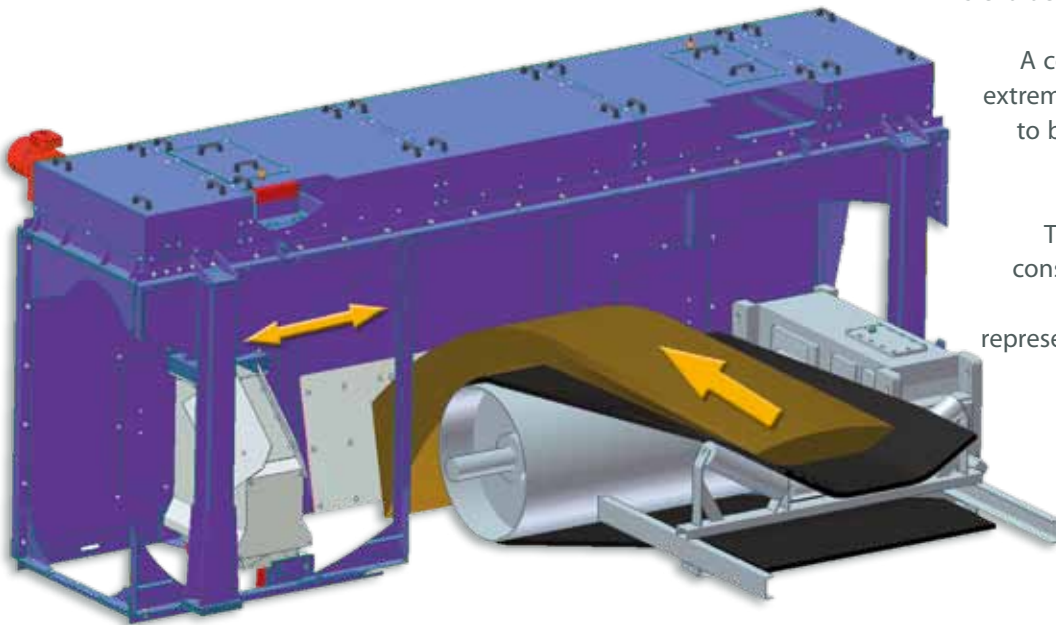

Slot vessel sample taker in material

Overview

The following selection of standardised machinery and equipment shows the wide scope of this sampling principle's potential:

- Slot vessel sampler in suspended execution
- Slot vessel sampler with lateral track
- Swivel arm sampler
- Downpipe sampler
- Pulp sampler
- Pipe spoon sample taker

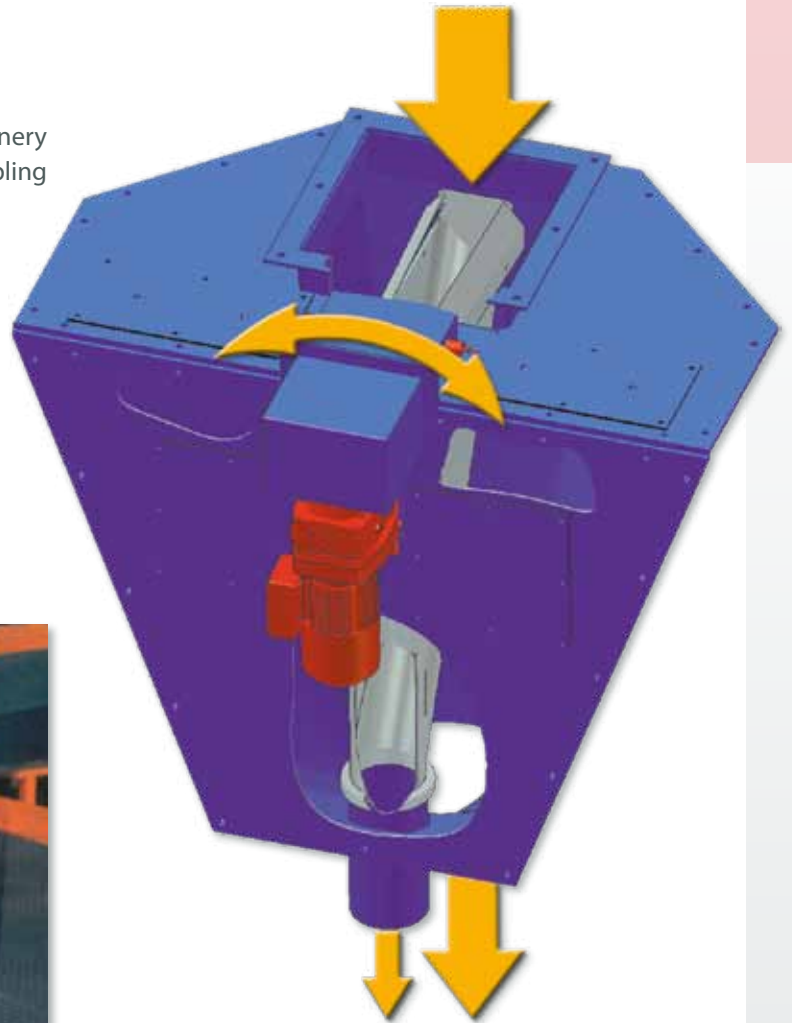

Principle of a pipe spoon sample taker



Slurry sampler to sample slurries



Pipe spoon sample taker

Comminution machinery

There are a number of machines in our range for comminuting products of varying hardness. Hammer mills, single and double-roll mills, jaw crushers, conical crushers, continuous vibration disk mills and eccentric vibration mills for milling for analysis fineness.

The product and the quality characteristics to be analysed are invariably decisive for selecting the best-suited comminution machine.



Jaw crusher EB 30/25



Single-roller mill EW 30/40



Hammer mill HM 6a

The most varied items of equipment are available to divide the sample. The pertinent standards are to be carefully observed with the dividers as well:

Included here are the minimum slot widths, speeds below 0.6 m/s., the removal of an adequate number of single samples (cuts) with the minimum quantity being taken into account, no demixing, etc. The figure of the "dividing ratio" important for dividers can be calculated as follows for our products:

$$x = \frac{SW}{u_T}$$

whereby x : dividing figure

u_T : divider circle circumference

SW : slot width of the material outlets
for the sample

The result is the dividing ratio 1 : x .

Turnstile divider

The turnstile divider is a divider that, with slight modifications, can be used for practically all products from cokes in lumps, plugged fine coal right up to super-fine-milled quick lime. The sampled material can be transferred to the divider's charging area without prior dosing, since it is thoroughly mixed and dosed prior to the dividing stage proper by the inwardly-directed raking arm.

The material transferred to the middle of the divider plate via the first raking arm is now uniformly transported in a spiral movement outwardly over the edge of the plate by a second raking arm and drops onto a conically worked sheet housing, which is partly recessed. The product dropping onto this recess is designated the "sample".

The material slipping to the middle of the plate via the cone is discharged as waste via the so-called gravity channel.

The turnstile divider offers the following advantages: This divider operates very reliably even with most and adhesive products through the forced guidance of the material stream through the raking arms and strippers. For divider regular cleaning, some types can be swung open by a third, increasing accessibility and minimizing cleaning time.

The dividing ratio can be varied by the recess in the conical section being closed by means of a side plate in the range of 1:4 up to 1:168 depending on the particular divider size concerned. Appointing two dividers consecutively enables dividing ratios far above 1: 1,000 to be realized.

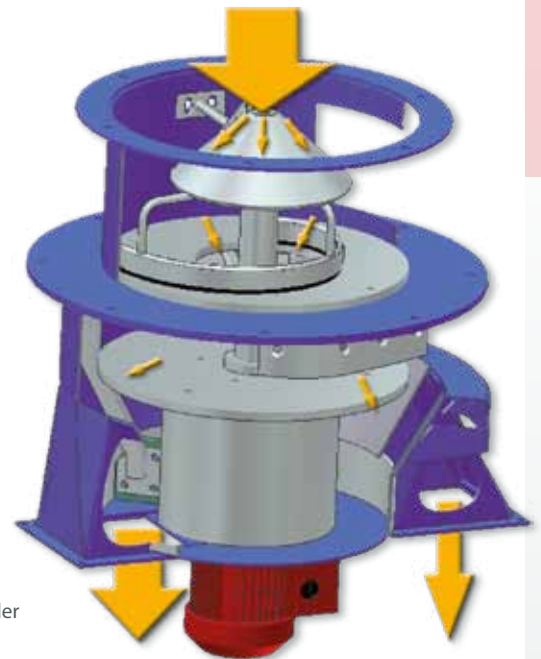

Principle of a turnstile divider



Turnstile divider 1200 A



Turnstile divider 370 FA

Dividers

Rotary divider

The rotary divider has a vertically appointed disk provided with openings which is rotated by a motor.

The sample material is uniformly fed to the divider via a dosage unit and guided onto the rotating disk. It passes through the opening in the disk as a "sample" or is deflected by the disk as a "reject".

The dividing ratio (1:2 up to 1:130 depending on the type concerned) in this divider can no longer be varied after production due to the simple design.

The divider is used for dividing dosable, pourable and hardly caking materials.

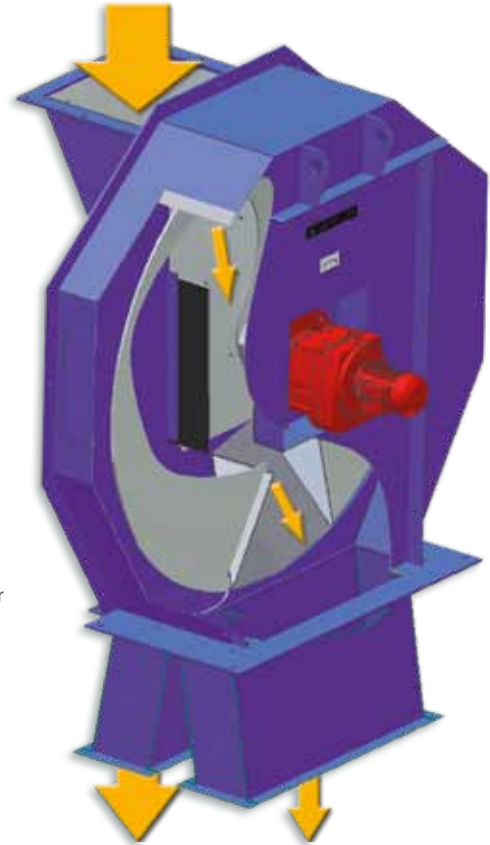

Principle of a rotary divider



Rotary divider, turnstile divider, sample collector



Rotary divider

Rotary pipe divider

With the rotary pipe divider, the uniformly added material stream is distributed into a funnel-shaped cone via a sloped rotating pipe.

The cone has recesses in the divider circle. The product passing through this recess is designated the "sample", the material collected via the funnel the "rejects".

The openings for the sample can be closed by means of a slide plate, resulting in a variably adjustable dividing ratio.

The rotary pipe divider can be implemented for easily pourable material not tending to plug. This divider can be cleaned through large inspection openings

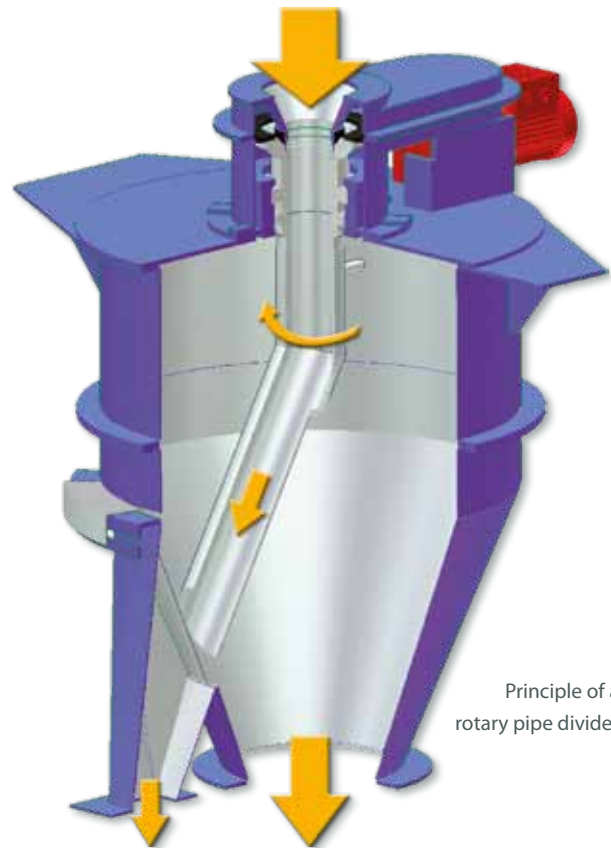

Principle of a rotary pipe divider



Rotary pipe divider DRT 500 with two sample outflows

Sample collectors, sample transport and laboratory instruments

Should samples be collected only at protracted time intervals, we offer the possibility of keeping them in so-called sample collectors of the most varying sizes until they are collected.

The sample bottles are placed in a roundabout and are turned to the next empty bottle when filled.

In the extensive range, you will find machinery and devices for transporting the samples, such as space-saving and encapsulated special belts, for screen analysis, drum tests, and further laboratory instruments for preparing the obtained samples for analysis.



Automatic Moisture Analyser System

AMAS (Automatic Moisture Analyser System)

This fully automatic system can determine the moisture content of bulk-material samples of up to 6 kg in weight. For this purpose, the AMAS can be integrated in an automatic sampling unit, thereby allowing the analysis to be carried out immediately after the sample has been taken from the material.

The AMAS process begins with the filling of the drying dish with the moist sample of bulk material. This is then spread evenly over the dish and weighed.

After a certain period of time for drying, the dish is removed from the oven, weighed, and then replaced in the oven.

This last step is repeated until the material is completely dry and the results of two successive weighing operations are identical. The dish is then emptied and cleaned to receive the next sample. The illustration shows the AMAS with an eccentric vibration-grinding mill for reducing the sample to fine particles in readiness for subsequent material analysis.

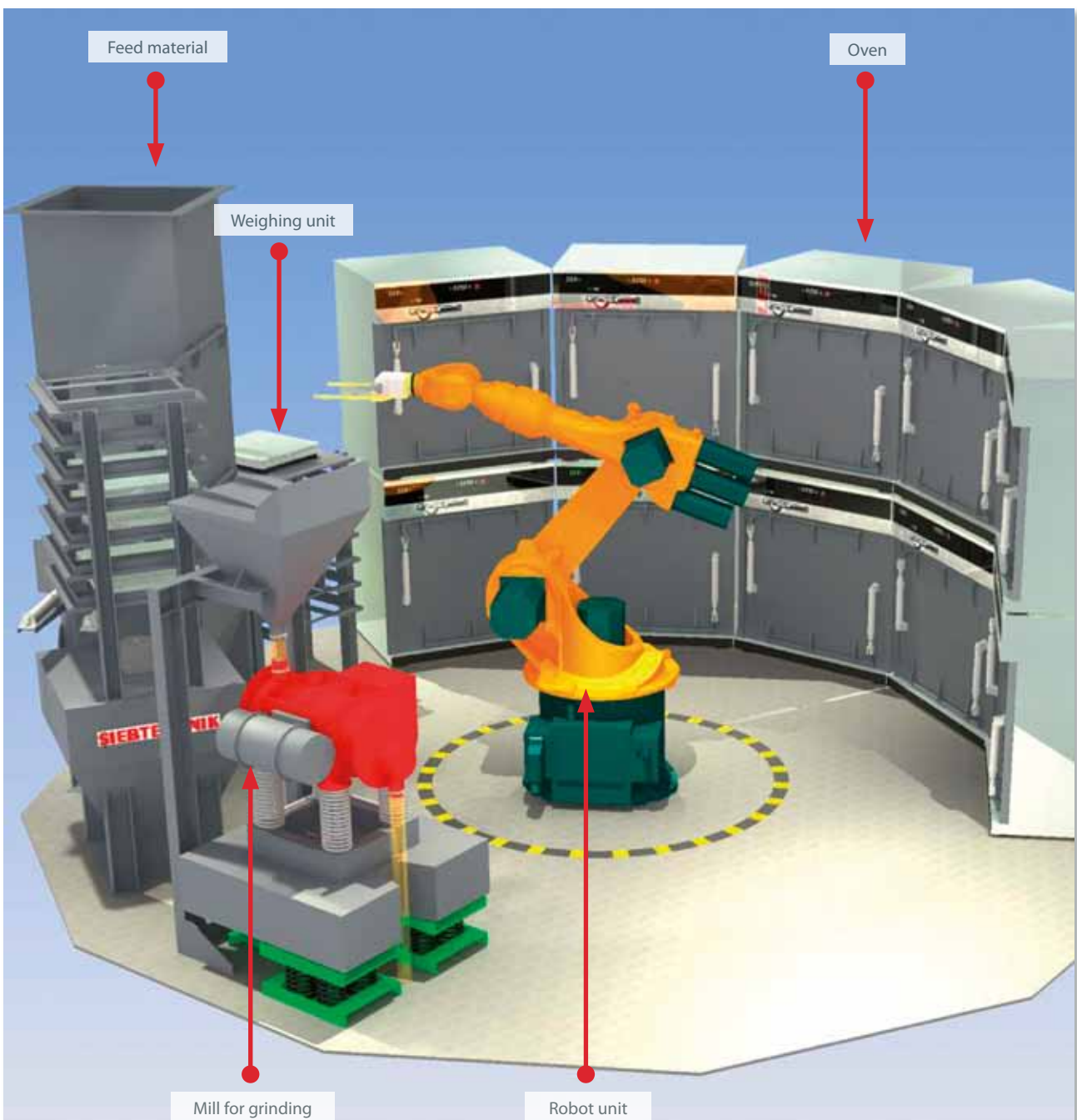

Sample taking of sand and gravel with automatic particle size determination

As shown in the illustration below, sampling devices combined with electronic testing equipment can determine the distribution of particle sizes in a bulk material and, at the same time, provide a sample for chemical analysis.

By means of the material drier integrated in the unit, it is possible to process even damp or wet materials before passing them on to the analysing unit.

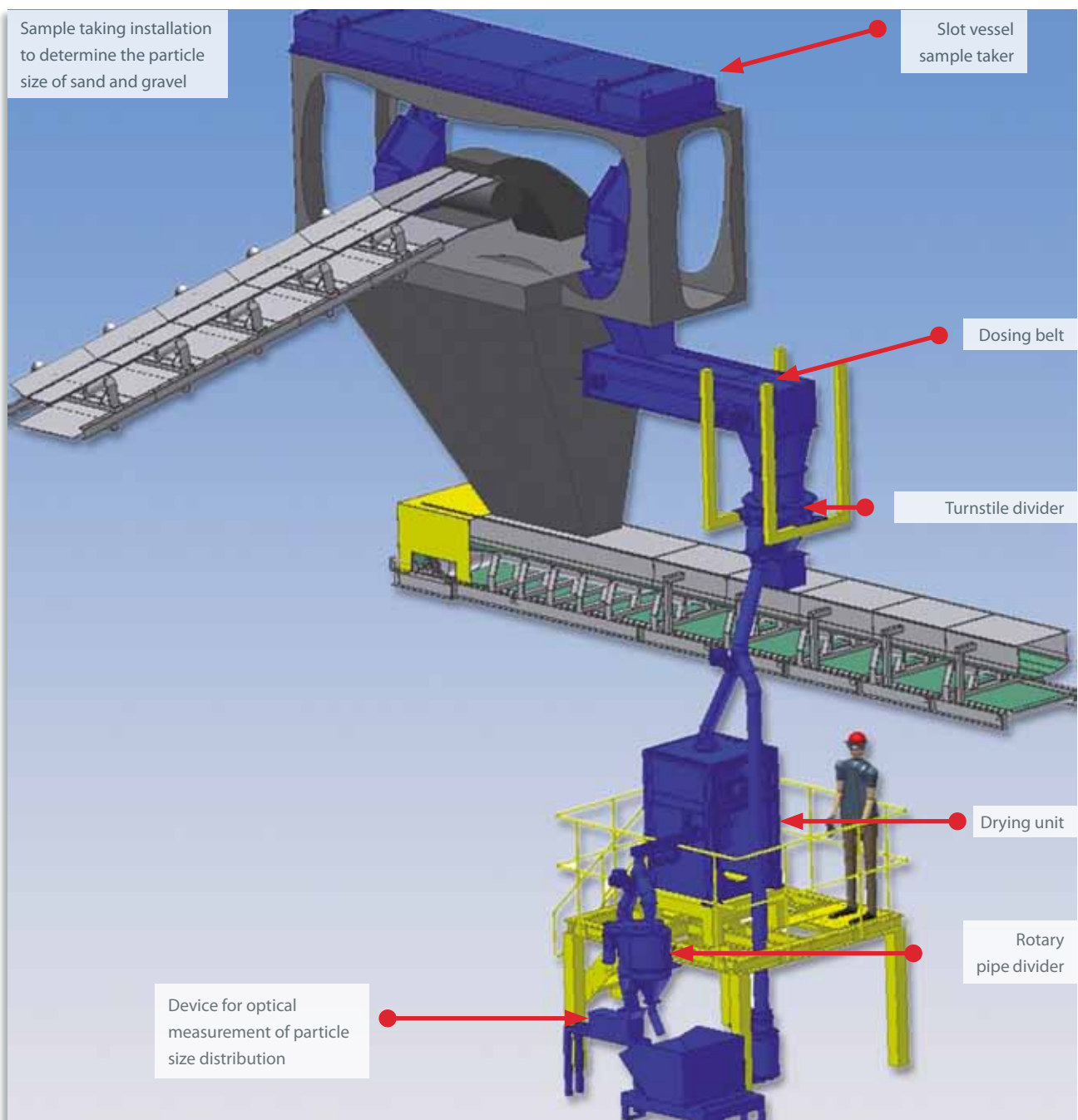

Testing sampling and sample preparation plants

All devices and instruments must be subjected to tests to establish whether the results from the samples obtained with these plants have systematic errors. A plant is tested for systematic errors by additional sampling according to a reference procedure.

The samples obtained through the two procedures are prepared according to the regulations, examined, and the results statistically evaluated.

If the structural and operational conditions admit it, reference sampling is preferably done by clearing a material cross section from a stopped conveyor. It is the general view that this type of sampling is not affected by a systematic error.

For this reason, one-sided deviations of the test results are regarded as indications of possible systematic errors within the plant to be tested and cause the individual units in the plant to be controlled.

The test data are evaluated within the scope of a T-test with the objective of establishing whether there is a significant, systematic deviation.

Automatic sampling plants must therefore be constructed in such a manner that the individual units employed are selected and designed with the necessary care and technical know-how of our planners and designers, so that uniform and permanent quality is ensured in continuous operation.



Sampling system for limestone



Sampling system for sand



Hammer sampler in the chemical industry



Sampling of gravel

Delivery Program

Screening Machines Process Equipment

circular and elliptical motion screens
double counterweight screens
multideck horizontal screen
round screens
jigs

Sampling Systems, Airtube Systems, Size Reduction Machines, Laboratory Equipment, Control Screening Machines and Automation

individual units and complete installations
for sample taking and preparation
airtube systems
jaw crushers
roller mills
hammer and hammer impact mills
eccentric-vibrating mills and ball mills
control screening machines
analytical screening machines
splitter
testing drums
automation

Centrifuges

scroll-screen centrifuges
pusher centrifuges
sliding discharge centrifuges
vibratory centrifuges
decanter centrifuges